

TH2 1,303 SQ. FT

INTERIOR UNIT

2 BED | 2.5 BATH | SINGLE GARAGE

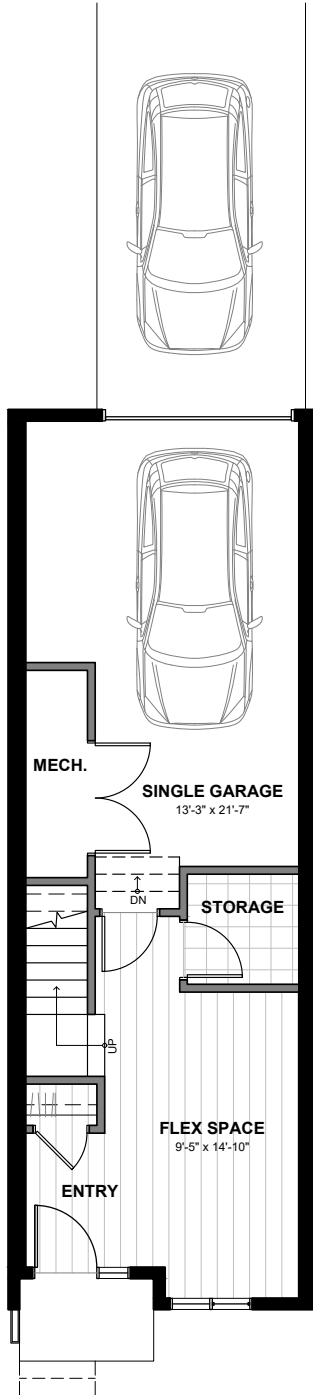

MAIN FLOOR
293 SQ. FT

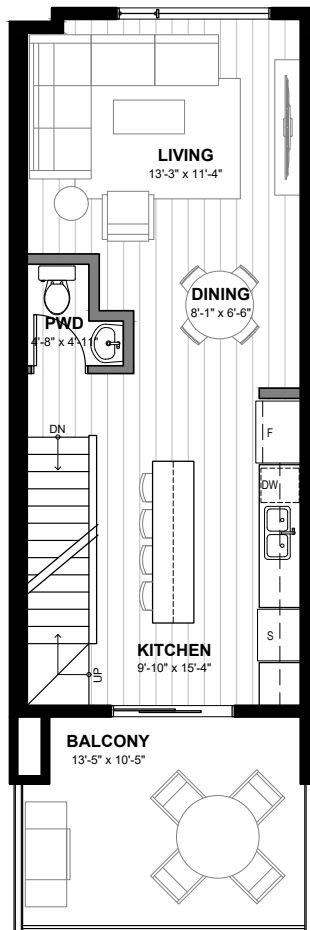

SECOND FLOOR
478 SQ. FT

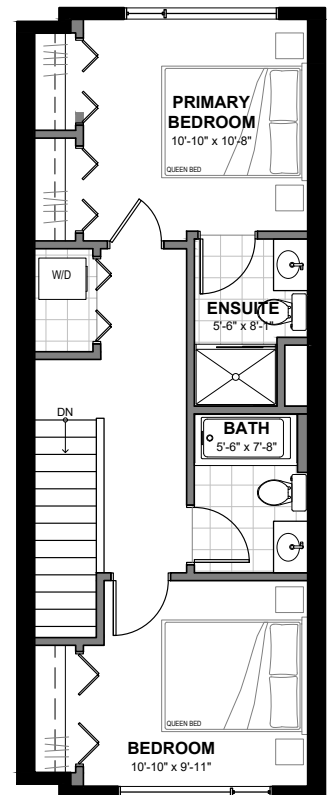

THIRD FLOOR
532 SQ. FT

Subject to the disclosure requirements set out in the Condominium Property Act (Alberta)(if applicable), the Developer reserves the right to make revisions if deems appropriate in its sole discretion to all plans, dimensions and specifications provided, including but not limited to column locations and window location and size. Actual usable floor space may vary from the stated floor area. The purchase price does not include any furniture. Renderings are artist's concepts only. This drawing contains information which is proprietary to and is the property of the Developer and may not be used, reproduced or disclosed in any manner other than in relation to the purchase of a condominium unit within this project without the permission of the Developer. E. & O. E. February 2023. Pricing subject to change without notice.

